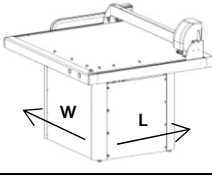
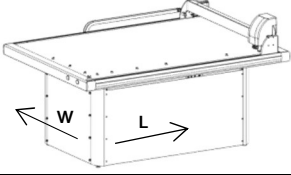

## GUNNAR AiOX OVERVIEW TECHNICAL DETAILS

Parameter	GUNNAR AiOX M	GUNNAR AiOX XL
		
Outer Dimensions L x W x H	130 x 160 x 121 cm   51 x 63 x 48"	210 x 160 x 121 cm   83 x 63 x 48"
Cutting Table Height	90 cm   36"	90 cm   36"
Max. Mat Board Sheet Size L x W	105 x 126 cm   41.3 x 49.6"	Full window 126 x 186 cm   49.6 x 73.2" COE 126 x 814 cm   49.6 x 32.0"
Max. Cutting Window Size l x w	Hybrid M 87.5 x 121 cm   34.5 x 47.6" Professional M 87.5 x 114 cm   34.5 x 44.9"	Hybrid XL 121 x 169 cm   47.6 x 66.5" Hybrid XL COE 121 x 163 cm   47.6 x 64.1" Professional XL 114 x 169 cm   44.9 x 66.5" Professional XL COE 114 x 163 cm   44.9 x 64.1"
Max. Cuttable Mat Board Thickness guaranteed	3,5 mm   0.14" (Professional: Foamboard up to 5mm possible)	
Mat Board Fixation Series Models	Turnable button clamp system, Vacuum available as option	
Machine Weight	140 kg   308 lbs	170 kg   375 lbs
Packaging Weight	70 kg   154 lbs	130 kg   286 lbs
Packaging Size L x W x H	168 x 142 x 85 cm   66 x 56 x 34"	225 x 164 x 85 cm   89 x 65 x 34"
Power Supply	230 V / 50 Hz / 6 A   115V / 60Hz / 10A	
Compressed Air Supply	Min 7 bar   Min 90 psi	
Cutter Operating Software	GMC 2.x or higher	
PC Interface	USB 2.0 or higher	
PC Operating System	Windows 10 or higher, 64bit	
PC Processor	i5 multi core processor, Gen 10 or newer	
PC Working Memory	Min 8GB RAM	

Functions	GUNNAR AiOX Hybrid	GUNNAR AiOX Professional
Cutting Head System	Integral Hybrid cutting head for 45° and 90° cuts	Fully synchronized double head system with two separate cutting heads for 45° and 90° cuts
45° Cut	X	X
90° Cut	X	X
Automatic change between 45° and 90° cut	X	X
Automatic change of blade cut debt for V-grooves	X	X
Fully automatic, dynamic blade dept adaption for all mat board thicknesses	X	-
Complete mat board cut without any tool or head change	X	X
Max. positioning speed	1'000 mm/s   40"/s	1'000 mm/s   40"/s
Max. cutting speed	600 mm/s   24"/s	800mm/s   32"/s
Warranty	50'000 openings or 2 years	400'000 openings or 2 years

Options	GUNNAR AiOX Hybrid	GUNNAR AiOX Professional
Vacuum table	X 230 V / 50 Hz / 30 A   220V / 60Hz / 30A	X 230 V / 50 Hz / 30 A   220V / 60Hz / 30A
Table mounting	X	X
Dual-Zone-Cutting, COE mode	X (XL only)	X (XL only)
T1 Tool	-	X
UTH Precision Pen Tool	X	X

Technical specifications may vary based on mat cutter options.